

mesytec **MPR-16-L** provides a state of the art multi channel charge integrating preamplifier, well suited for silicon or gas detectors. The MPR-16-LX can be combined with mesytec spectroscopy amplifier - discriminator unit STM16+ with Lemo input. See also MPR16-D type to drive differential lines.

Features:

- 16 channel compact module
- Very low power dissipation (4 V type)
- Sensitivity switch, factor 5
- ESD input protection
- Lemo output, can drive terminated BNC lines
- Pulser input
- Bias voltage up to ± 400 V
- PCB module available for vacuum use



Schematics:

(for MPR-16)

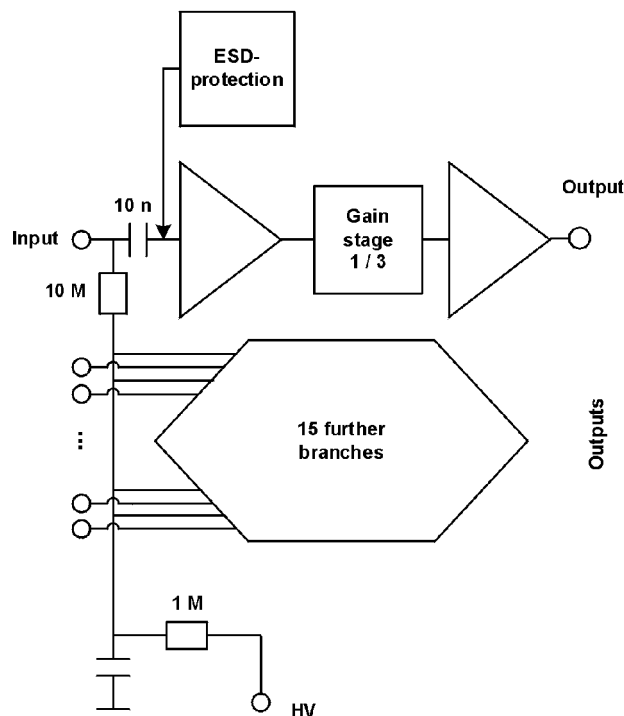

Technical Data

Energy ranges

The MPR-16 provides a switch to amplify the output signal by a factor of 5. This helps to provide large output signals even at low charge depositions and thus provides good noise immunity. Standard types are 100 MeV, 500 MeV and 2.5 GeV. Other ranges can be realised on request.

Input stage

- Input connector(s): SubD 25 female connector (for a 16 channel unit)
- Pin assignment:

Function	connector	Function	connector
Sig-gnd	1,2,7,12,13,14,15,25	Cha 9	19
Cha 1	11	Cha 10	6
Cha 2	23	Cha 11	18
Cha 3	10	Cha 12	5
Cha 4	22	Cha 13	17
Cha 5	9	Cha 14	4
Cha 6	21	Cha 15	16
Cha 7	8	Cha 16	3
Cha 8	20	guardring	24

- Positive and negative charge can be amplified equally.
- The guardring output (24) is connected via R-C-R filter (100 k Ω , 10 nF, 100 k Ω) to the common detector bias input.

Output stage

- Lemo output: two options available
 - low power drivers for ± 4 V output
 - high power drivers for ± 10 V output
- Rise time 10 ns @ 0 pF input capacity
- Rise time 25 ns @ 350 pF input capacity

Noise

Power modes can be selected by a jumper on the PCB. High Power mode reduces noise, while low Power mode may be useful for in vacuum use.

power mode	shaping time	MPR16-LX-100
	σ / FWHM [us]	noise [keV] FWHM
LP	0.4 / 1	(5 + 0.06/pF)
	1 / 2.5	(4 + 0.04/pF)
HP	0.4 / 1	(5 + 0.04/pF)
	1 / 2.5	(4 + 0.027/pF)

For MPR16 max range > 100 MeV:
noise < 1E-4 of max range @ 100 pF input capacity

Pulsar input

The pulser is internally distributed to individual charge termination capacities. Tolerances ± 10 %.

MPR16-LX-100	MPR16-LX-300
0.78 pF <i>or</i> 1.13 pF (17 / 25 MeV/V)	2.4 pF (50 MeV/V)

Detector bias input

- Lemo connector
- Maximum voltage ± 400 V
- When connected detector side must be on ground level: terminate bias input with 50 Ω

Ground connections

- Ground screws on front and rear side
- There are two different ground connections: input and output ground.
- Input ground is connected to the vacuum vessel if the setup is not isolated (i.e. isolated flange).
- In critical environment the output ground can be connected to the NIM electronics.

Power connector

- SubD9 connector:
 - 1, 2 = gnd
 - 3 = +6 V
 - 4 = +12 V
 - 5 = -6 V
 - 9 = -12V (only for MPR16-L10- versions with 10V output driver)

Pinout of on board power connector for PCB version

- gnd : 1,3,10,11,12
- +12 V : 7
- +6 V : 5
- -6 V : 9
- LED+ : 13 ("power ok" LED)
- LED- : 14

Power consumption for 16 channels

4 V output version

(well suited for in vacuum use):

Parameter	MPR16-LX-100	MPR16-L4-300 MPR16-L4-500 MPR16-L4-2500
	current [mA]	
LP/HP +6 V	50	50
LP/HP -6 V	50	50
LP +12 V	40	-
HP +12 V	80	40
total power LP-mode	1.1 W	-
total power HP-mode	1.6 W	1.1 W

LP = low power mode, HP = high power mode

10V output version:

Parameter	MPR16-LX-100	MPR16-L10-300 MPR16-L10-500 MPR16-L10-2500
	current [mA]	
LP/HP +6 V	40	40
LP/HP -6 V	40	40
LP/HP -12 V	90	90
LP +12 V	110	-
HP +12 V	150	110
total power LP-mode	2.9 W	-
total power HP-mode	3.4 W	2.9 W

LP = low power mode, HP = high power mode

Cooling

Due to the low power consumption cooling is in general not necessary.

For **in vacuum use**, select low power mode if possible. The power of a single PCB can be dissipated without problems. If several PCBs are densely packed, heat conducting metal sheets should be placed in between the PCBs.

Avoid to warm up silicon detectors by the dissipated power.

MPR16-L with 10 V output driver are not recommended for in vacuum use.

Dimensions

- Length : 173 mm (without connectors)
- Width : 105 mm
- Height : 67 mm